

I-PRO 2 BOWLS, WITH MECHANICAL CONTROL AND LIGHTED PANEL

LED
Lights

ETANK
TECHNOLOGY



General Features

I-PRO2ML

CRATHCO

I-PRO 2 BOWLS, WITH MECHANICAL CONTROL AND LIGHTED PANEL

I-PRO 2 MECHANICAL LUCE is a professional slush machine with n. 2 I-Tank insulated bowls, 11 litres each, mechanical control and LED-lighted frontal panel.

Every detail has been studied to create a unique equipment thanks to the numerous patents and innovations available for this model.

This equipment has the I-Tank insulated tank as standard. The shape of the tanks, which work independently, guarantees a natural mixing effect for an optimal consistency of the product.

The look of this equipment is modern and eye-catching, thanks to the LED-light system that illuminates the product inside the tank and thanks to the LED-lighted frontal panel.

The equipment can dispense: slushies, milkshakes and cold drinks.

I-PRO is an ideal slush machine for bars, amusement parks, fast food chains, kiosks, restaurants, water parks and much more.

I-PRO 2 BOWLS, WITH MECHANICAL CONTROL AND LIGHTED PANEL

Specifications

- The ITANK™ Technology prevents ice accumulation on the outer side of the bowl, reducing condensation and increasing the cooling power of the machine.
- Ideal for the production of slush.
- Bowl shape allows a natural mixing action to ensure an optimum consistency of the product.
- Customizable lid merchandiser and back graphic.
- Ideal for operators who want an innovative and distinctive equipment. Mechanical keypad allows for setting of cooling and defrost modes.
- The insulated tank guarantees higher cooling efficiency and lower effect of the external temperature on product's preparation and maintenance time reducing condense and draining; it is the best solution in hot climate conditions.
- The front illuminated panel provides customers with the opportunity to advertise their product and maximise impulse buying.

Construction

- Electromechanical control.
- Sliding drip tray.
- Optional Autofill Lid System available: for the automatic filling of the tanks
- Slush machine with 2x11-litres insulated bowls

I-PRO 2 BOWLS, WITH MECHANICAL CONTROL AND LIGHTED PANEL

Electric

Supply voltage:	220-240 V / 1 ph / 50 Hz
Electrical power max.:	0.78 kW
Current consumption:	4.3 Amps
Plug type:	CE-SCHUKO

Key Information:

Number of bowls:	2
Bowl's capacity:	11 lt
Control board:	Mechanical
Dimensions, Width:	400 mm
Dimensions, Depth:	580 mm
Dimensions, Height:	870 mm
Net weight:	60 kg

Refrigeration Data

Refrigerant gas:	R290
------------------	------

Certifications



The company reserves the right to make modifications to the products without prior notice. All information correct at time of printing.

2026.03.31

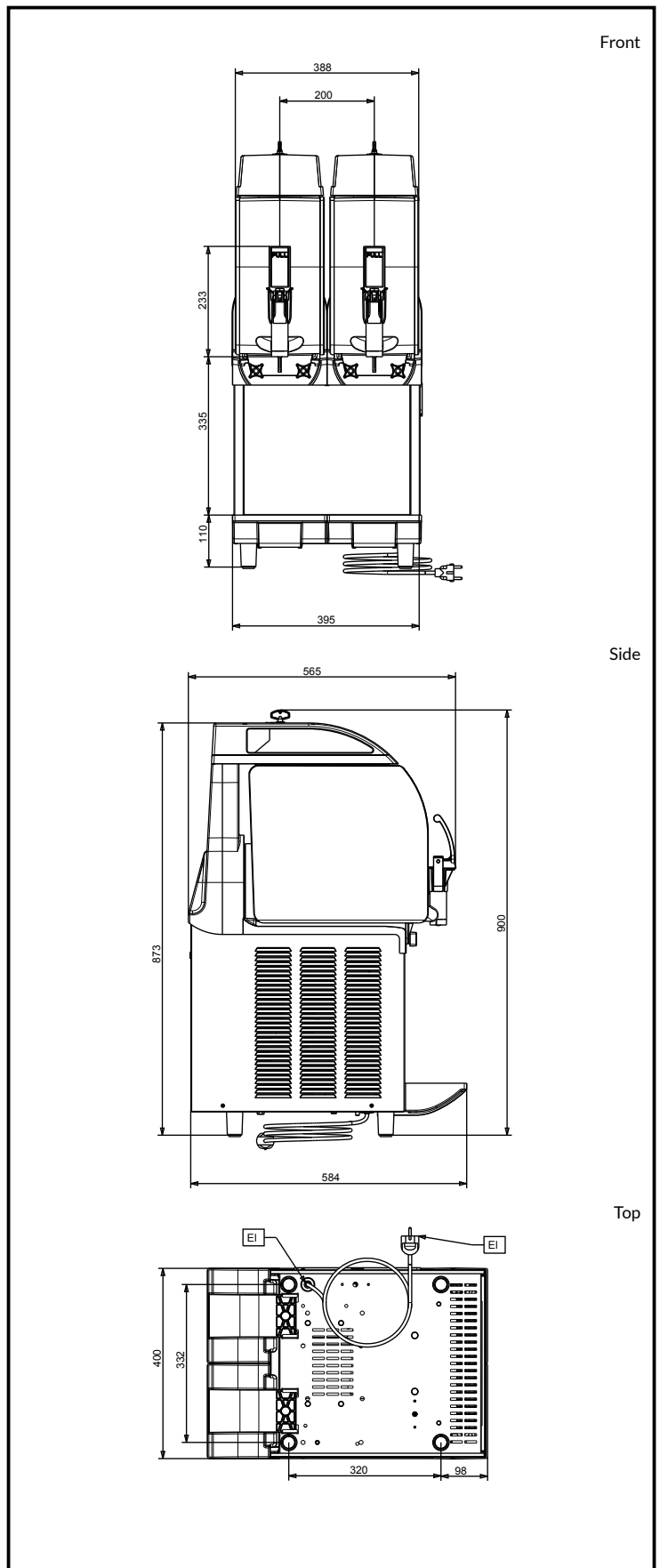

CRATHCO

www.crathco.drink-systems.com
infocrathco@electroluxprofessional.com